

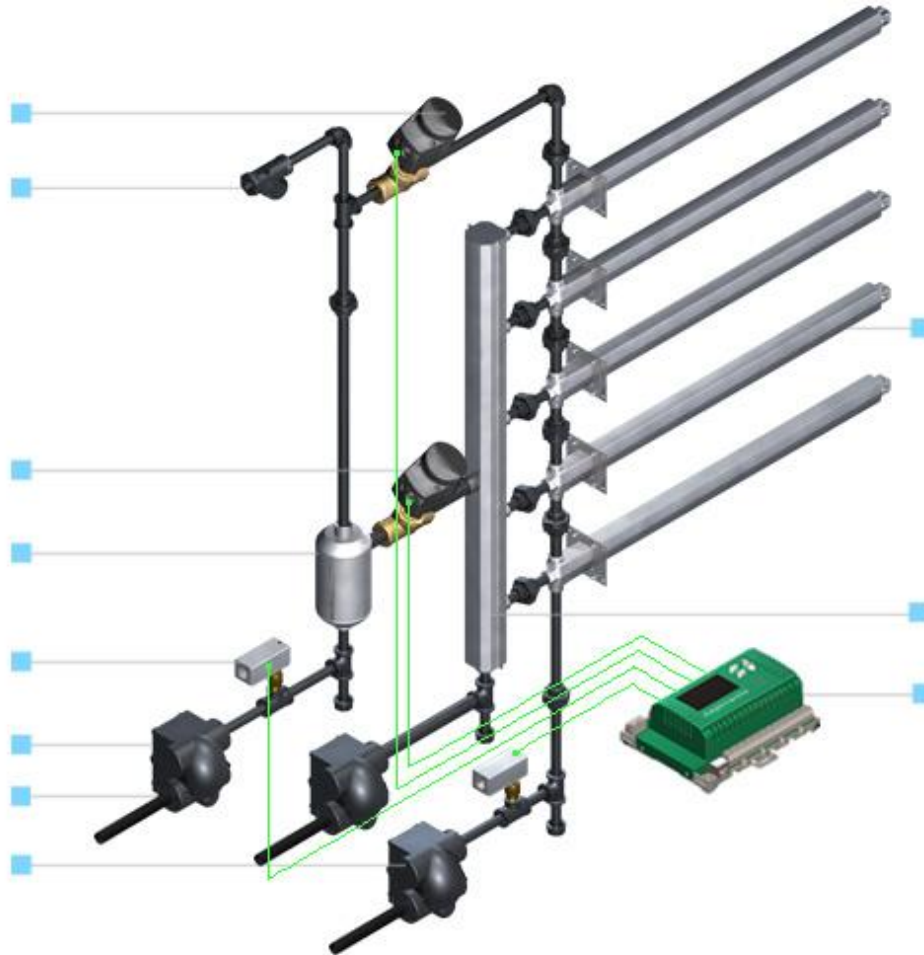

neptronic®

Direct Steam Injection Humidifier

SKD-J (Jacketed) Series



Installation Instructions and User Manual

For the following configurations:

- Jacketed Single Tube
- Mini Rack
- Multi-Tube

READ AND SAVE THESE INSTRUCTIONS

Foreword and Safety Instructions

Neptronic Company Overview

Founded in 1976, we're a private corporation that designs, manufactures and distributes products for the HVAC industry. Our product line includes intelligent controllers, electronic actuators, actuated valves, humidifiers and electric heaters.

Our products are designed and manufactured by over 250 dedicated employees in our 7,500 m² (80,000 ft²) state-of-the-art facility located in Montreal, Canada. Using a vertical integration model, our entire manufacturing chain is under one roof from software and hardware development, to SMT circuit board assembly, to sheet metal fabrication, to product testing ensuring that our products are engineered to last.

We currently hold several national and international patents and with our continued commitment to research and development, we provide innovative products and technologies for the ever-evolving challenges of the HVAC industry. Exporting over 70% of our sales, we have an exclusive distribution network around the globe that provides comprehensive solutions to our worldwide customers.

About the Manual

These installation and operation instructions have been developed to facilitate the installation of the Direct Steam Injection Humidifier.

- The strict application of these instructions will ensure the conformity of your installation and operation as per the manufacturer's recommendations.
- The application of these instructions is one of the conditions for the application of the warranty.
- The application of these instructions does not ensure, at any time conformity to procedures, regulation or local codes, regarding electric installation and connection to local water supply.

This product has been declared to conform to the applicable Canadian and American safety standards and directives and bear the CSA (c) & (us) mark. The Certificate of Conformity, CSA is available, upon request with the manufacturer.

2018©: All rights reserved. This document cannot be reproduced totally or partially by any means whether, electronic, mechanical, photocopy, recording or other, without prior written authorization of Neptronic.

Electricity



All work concerned with electrical installation **MUST** only be performed by skilled and qualified technical personnel such as an electrician or a technician with appropriate training). The customer is always responsible for ensuring the suitability of the technical personnel.

Please observe the local regulations concerning the provision of electrical installations.

Correct Use

Neptronic systems and its products are designed only for humidification use. Any other application is not considered appropriate for the intended purpose. The manufacturer cannot be made liable for any damage resulting from incorrect use.

General Warranty

This product is subject to the terms and conditions described at neptronic.com/sales-conditions.



List of Figures

Illustration 1 - Jacketed Single Tube	3
Illustration 2- Mini Rack	4
Illustration 3 - Multi-Tube	5
Illustration 4 - Multi-Tube for Large Capacities	6
Illustration 5 - Manifold Installation	9
Illustration 6 - End Mounting Bracket and Escutcheon Plate	9
Illustration 7 - Steam Header with Union	10
Illustration 8 - Mini Rack	10
Illustration 9 - Control Valve Orientation and Control Valve Angle.....	11
Illustration 10 - Control Valve Connection to Steam Distributor without Header	11
Illustration 11 - Control Valve Connection with Header	12
Illustration 12 - Separator Proper Installation	13
Illustration 13 - Separator Incorrect Installation	13
Illustration 14 - Single Steam Distributor Separator Correct Installation	13
Illustration 15 - Single Steam Distributor Separator Incorrect Installation	13
Illustration 16 - Separator Connection to Control Valve	14
Illustration 17 - Temperature Sensor Separator Installation	14
Illustration 18 - Temperature Sensor Jacket Installation	15
Illustration 19 - Separator Steam Trap Installation.....	15
Illustration 20 - Steam Trap Installation: Distance from Temperature Sensor	16
Illustration 21 - Steam Trap Installation (Mini Rack and Multi-Tube)	16
Illustration 22 - Control Valve Orientation and Control Valve Angle.....	17
Illustration 23 - Jacketed Single Tube	18
Illustration 24 - Mini Rack and Multi-Tube	18

Contents

Technical Specifications	1
Product Description	1
Configurations.....	3
Jacketed Single Tube.....	3
Mini Rack.....	4
Multi-Tube	5
Large Capacity Multi-Tube	6
Handling and Packing.....	7
Installation Overview	8
Installation Method Statement.....	8
Stage 1 – Steam Jacketed Distributor Installation	9
Stage 2 – Steam Header Installation.....	10
Stage 3 – Control Valve (AM060) Installation.....	11
Stage 4 – Steam Separator Installation.....	13
Stage 5 – Temperature Sensor Installation.....	14
Stage 6 – Float and Thermostatic Steam Trap Installation	15
Stage 7 – Isolating Valve (AT060) Installation.....	17
Stage 8 – Y-Strainer Installation.....	17
Stage 9 – Electronic Steam Controller (SKDESC-J)	19
Initial Verification.....	33
Installation	33
Electrical.....	33
Drain if Needed (Mini Rack or Multi-Tube).....	33
Steam Supply	33
Controls.....	33
Start-Up Procedure	34
Start-up	34
Safety Test.....	34
Reset the Set Point and Control Mode	34
End	34
Notes.....	35

Technical Specifications

Product Description

The Direct Steam Injection Humidifier injects and disperses atmospheric or low pressure steam into a building's air supply system to attain and maintain the desired humidity level. It uses steam from an in-house boiler to humidify the air.

The Direct Steam Injection Humidifier is controlled by an Electronic Steam Controller (SKDESC-J) that has been specifically designed to control and operate the humidifier. It comes with user-friendly features such as easy start-up and diagnostics, large LCD display, simple configuration options, and factory configured settings. It controls the sequence of operations to optimize energy efficiency and prevents condensate ejection.

The following are the features of the Direct Steam Injection Humidifier and their functions:

- **Jacketed Tube Steam Distribution.** The steam dispersion tubes are made with stainless steel (1 3/8"). The jacketed tube steam distribution consists of a single tube or multiple horizontal tubes on a common vertical header. Upon a demand for humidity, the SKDESC-J controller opens the isolating valve to preheat the outer jacket. This prevents any condensate from forming in the inner tube that could wet the duct or AHU floor when steam is flowing through the tubes' nozzles. When the jacket reaches its operating temperature, the ESC controller slowly opens the steam modulating valve feeding steam directly into the inner tube(s). The steam escapes the tube(s) through multiple calibrated nozzles and mixes with the airflow to maintain the desired humidity level.

The following configurations are available with the jacketed tube steam distribution:

- Single Tube
- Multi-Tube
- Mini Rack

Each configuration suits a specific requirement and provides the following advantages:

- Low, medium, and high capacity applications
- Average and short non-wetting distances
- Duct, AHU, and limited space installations
- **Separator.** The separator is constructed with stainless steel. The separator supplies condensate-free steam to the steam control valve and discharges condensate to the steam trap.
- **Control Valves.** The Direct Steam Injection Humidifier comes with normally closed globe valve with equal percentage flow characteristics to control the flow of steam. It comes in variants such as bronze body and brass trim (stainless steel trim optional). The linear electric actuator (AM060) is equipped with a heat shield. The control valves provide full modulation of the low pressure steam flow for a better control of the humidity level.
- **Isolating Valves.** The valves are the normally closed globe valve with bronze body and brass trim (stainless steel trim optional), attached to a linear electric actuator (AT060). The valves control supply of the steam to the jacket in a multi-tube configuration or to the heat exchanger in a Direct Steam Injection Humidifier.
- **Electronic Steam Controller (SKDESC-J).** The SKDESC-J is a microprocessor based steam controller equipped with a backlit LCD display that allows programming the humidity setpoints and monitoring parameters such as actual humidity, airflow switch, interlock, temperature sensors efficient and easy.



- *Strainer.* The strainer strains foreign matter from pipelines and protects the components of the steam humidifier.
- *RTD Temperature Sensors.* The Direct Steam Injection Humidifier comes with RTD temperature sensors integrated in a brass thermowell. The temperature sensors monitor steam temperature and detect abnormal condensate levels to ensure safe operations.
- *Float and Thermostatic Steam Trap.* The design comes with universal four port design, all stainless steel internal components with the option of a stainless steel body construction as well. The Float and thermostat eliminates condensate from the steam line.

Configurations

The following configurations are available for Direct Steam Injection Humidifier.

Jacketed Single Tube

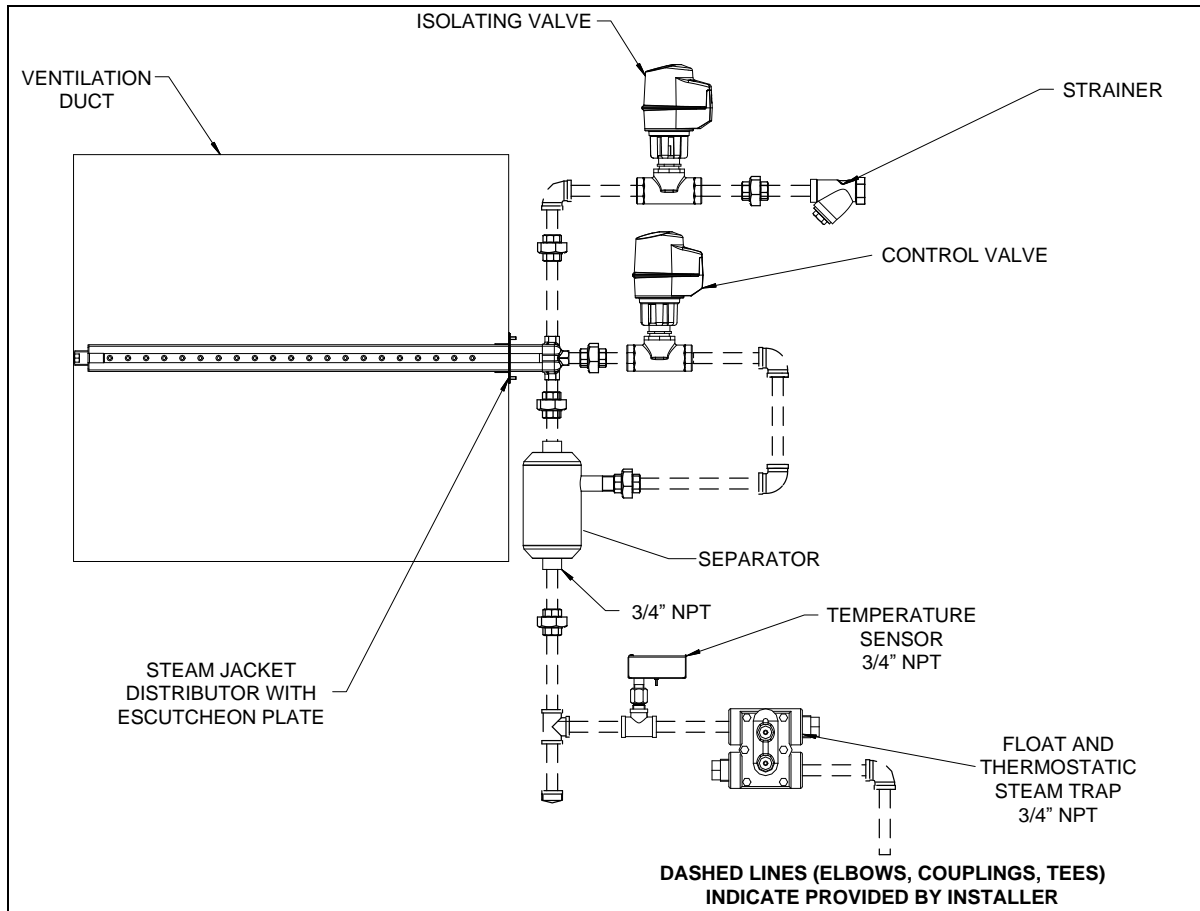

Illustration 1 - Jacketed Single Tube

Mini Rack

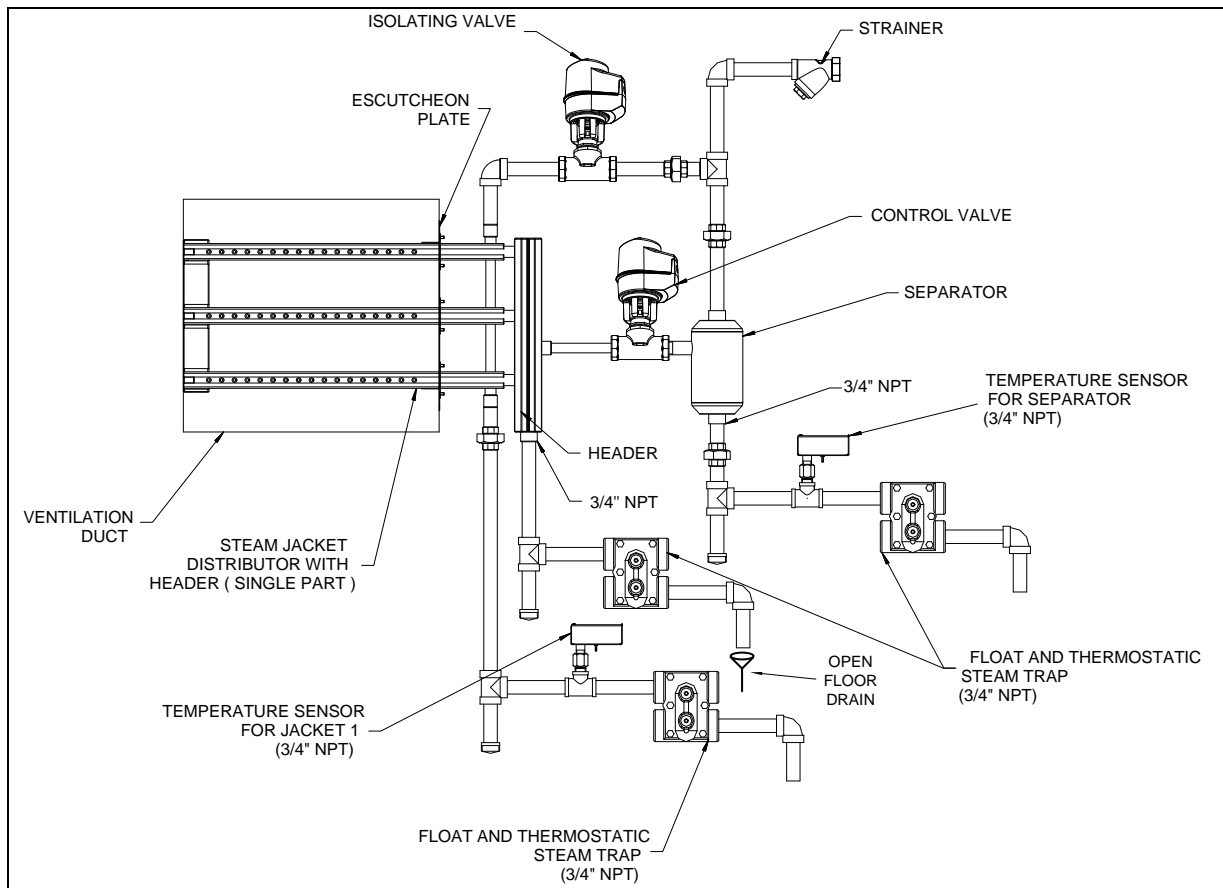

Illustration 2 - Mini Rack



Multi-Tube

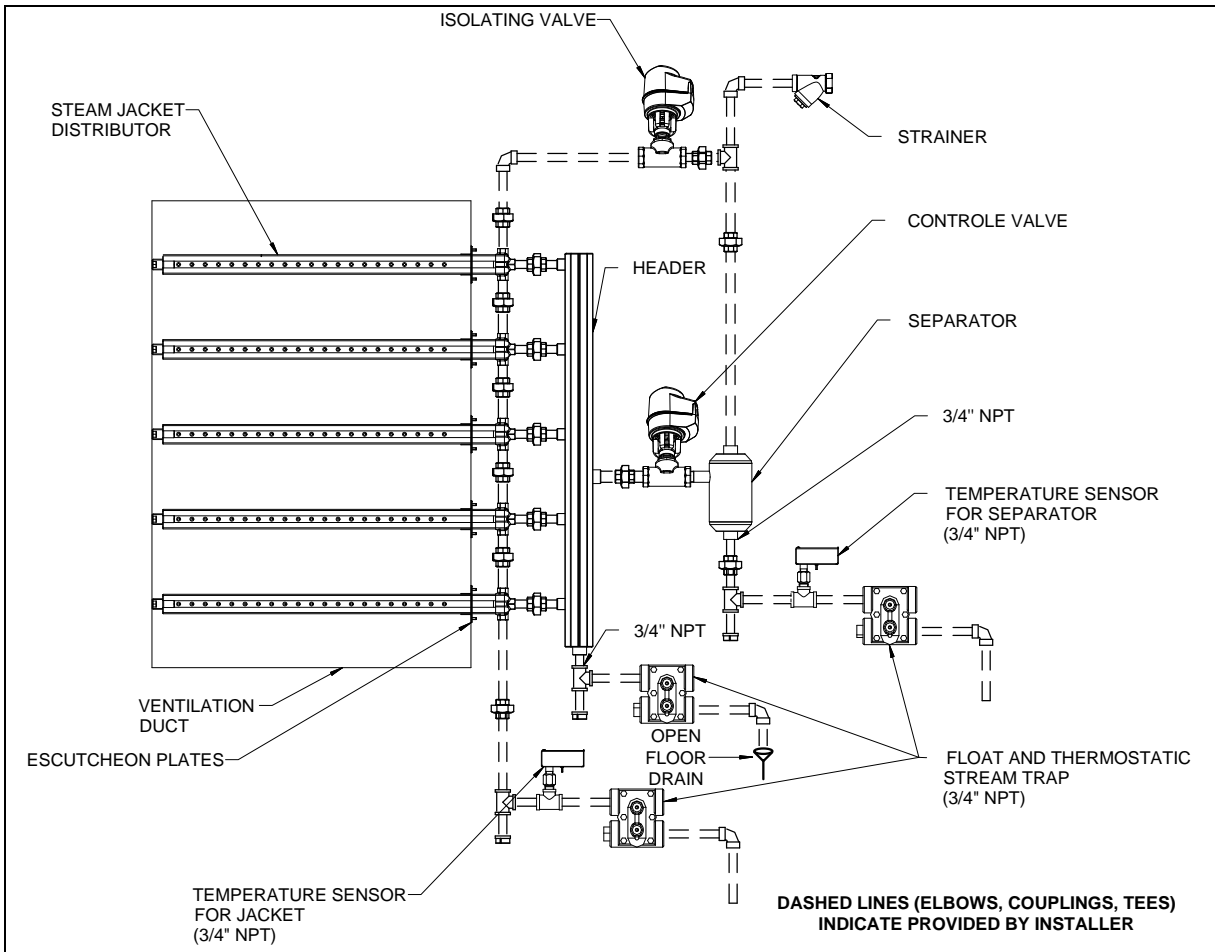

Illustration 3 - Multi-Tube

Large Capacity Multi-Tube

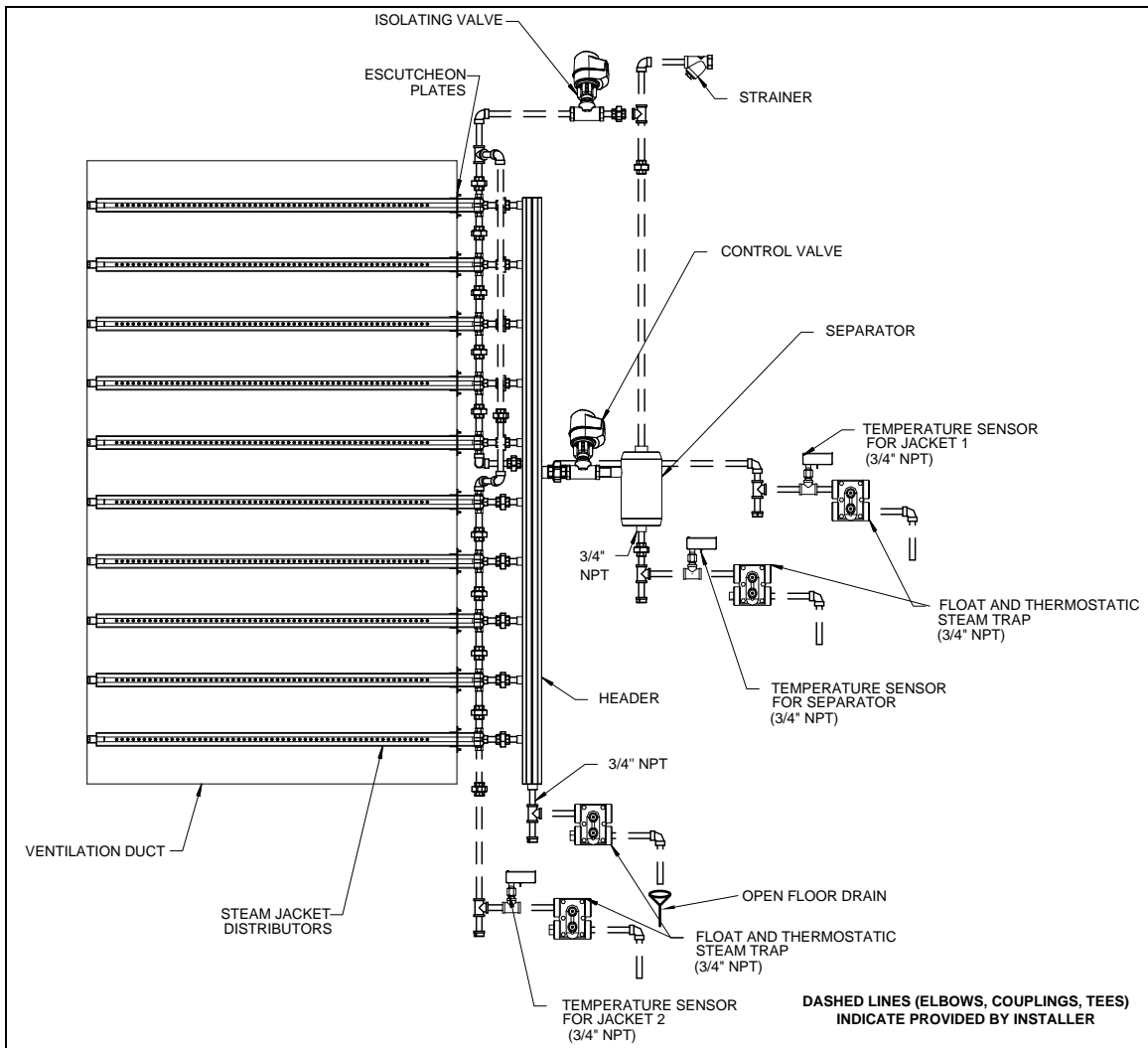

Illustration 4 - Multi-Tube for Large Capacities

Handling and Packing

Handling and Lifting



Lifting or handling **MUST** be carried out by trained and qualified personnel. Ensure that the lifting operation has been properly planned, assessed for risk and that the equipment has been checked by a competent Health & Safety representative, and effective control measures are in place.

It is the customer's responsibility to ensure that the operators are trained in handling heavy goods and to enforce the relevant lifting regulations.

The Direct Steam Injection Humidifier **MUST** always be handled and lifted with care and must remain in its original packaging for as long as possible prior to installation.

The Direct Steam Injection Humidifier package may be carried using a forklift from the underside. Caution must be exercised to ensure balanced load before lifting.

Unpacking

The Direct Steam Injection Humidifier is shipped inside carton boxes or in a wooden crate. Remove packing and skids prior to commissioning.

Installation Overview



All installation work must comply with local regulations.

All work related to the installation of the Direct Steam Injection Humidifier **MUST** only be performed by skilled and qualified technical personnel such as plumbers or technicians with appropriate training. The customer is responsible for ensuring their suitability.

For the installation of the Direct Steam Injection Humidifier and associated components, there are no specific tooling requirements.

Installation Method Statement

Stage 1 – Steam Jacketed Distributor Installation

Stage 2 – Steam Header Installation (only with Mini Rack and Multi-Tube models)

Stage 3 – Control Valve (AM060) Installation

Stage 4 – Steam Separator Installation

Stage 5 – Temperature Sensor Installation

Stage 6 – Float and Thermostatic Steam Trap Installation

Stage 7 – Isolating Valve (AT060) Installation

Stage 8 – Y-Strainer Installation

Stage 9 – Electronic Steam Controller (SKDESC-J)

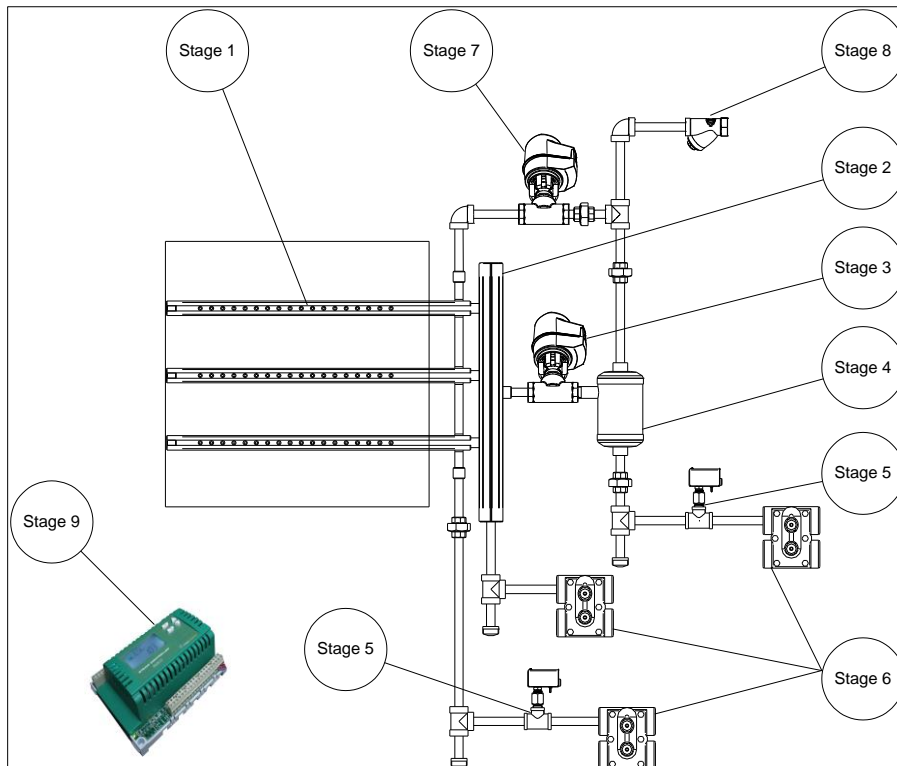

Stage 1 – Steam Jacketed Distributor Installation

General Considerations



Any installation work must be carried out by suitably qualified personnel.

Consider the following points before deciding the location for the Direct Steam Injection Humidifier steam distribution system:

- Plan a location that is easy to access and permits an easy inspection and servicing of the humidifier.
- Do not install the humidifier where failure of the appliance could cause damage to the building structure or to other expensive equipment.
- Verify that the construction of the duct or AHU wall is suitable to support the steam distributors through the duration of the installation life.

Positioning the Steam Distributors

- The steam distributors must be installed to ensure that the visible steam trail is kept to the shortest possible length.
- Steam nozzles must face the airflow to minimize the absorption and non-wetting distance.
- Locate the steam distributors far enough from elbow or fan to be in laminar air flow to ensure proper evaporation distance.
- There must be sufficient straight duct downstream from the steam distributors for absorption of the steam.

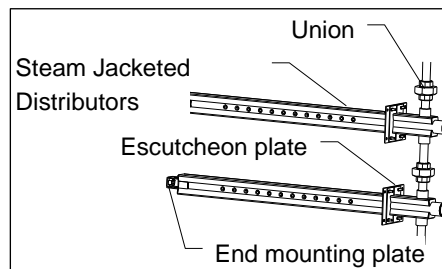

Illustration 5 - Manifold Installation

- For Jacketed Single Tube applications, position the steam distributor in the middle of the duct.
- For Multi-Tube, position the steam distributors so that the distance between them is the same. Use proper size unions to connect the jacket of each steam distributor together.
- For Mini Rack models, position the system evenly so that the spacing between the top distributors and the duct/AHU is the same as the bottom distributors and the duct/AHU.
- Use metal screws to mount the escutcheon plate to the wall of the duct or AHU.
- Secure the end of the steam distributor with 3/8" (10mm) rods either vertically or horizontally.

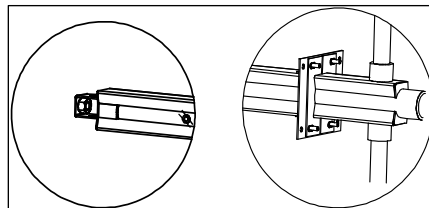

Illustration 6 - End Mounting Bracket and Escutcheon Plate



Stage 2 – Steam Header Installation



Any installation work must be carried out by suitably qualified personnel.

Steam Header Installation (Mini Rack and Multi-Tube only)

- Align the outlets of the steam header with the steam inlet of each steam distributor.
- For Multi-Tube, use proper size union to connect the steam header to the steam distributors. Refer to *Illustration 7 - Steam Header with Union*. The distance between the header and the steam distributor's inlet port must not exceed 8" (203 mm) and both header and steam distributor ports must be aligned, no elbows can be used to pipe the connection.
- For Mini Rack models, the connections between the steam header and the steam jacketed distributors are assembled at the factory. The steam distributors and the header assembly come as separate, single parts.

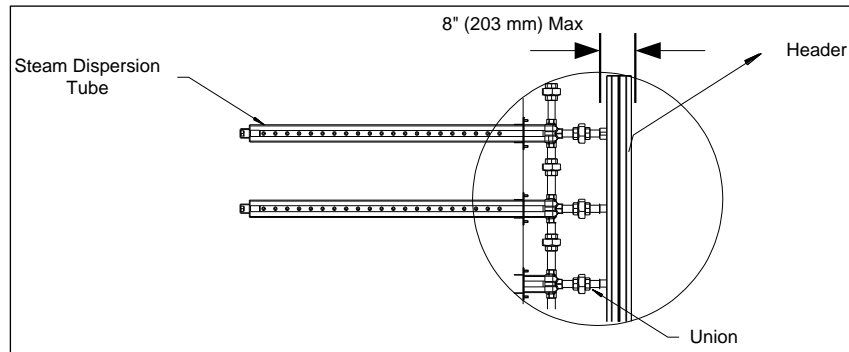

Illustration 7 - Steam Header with Union

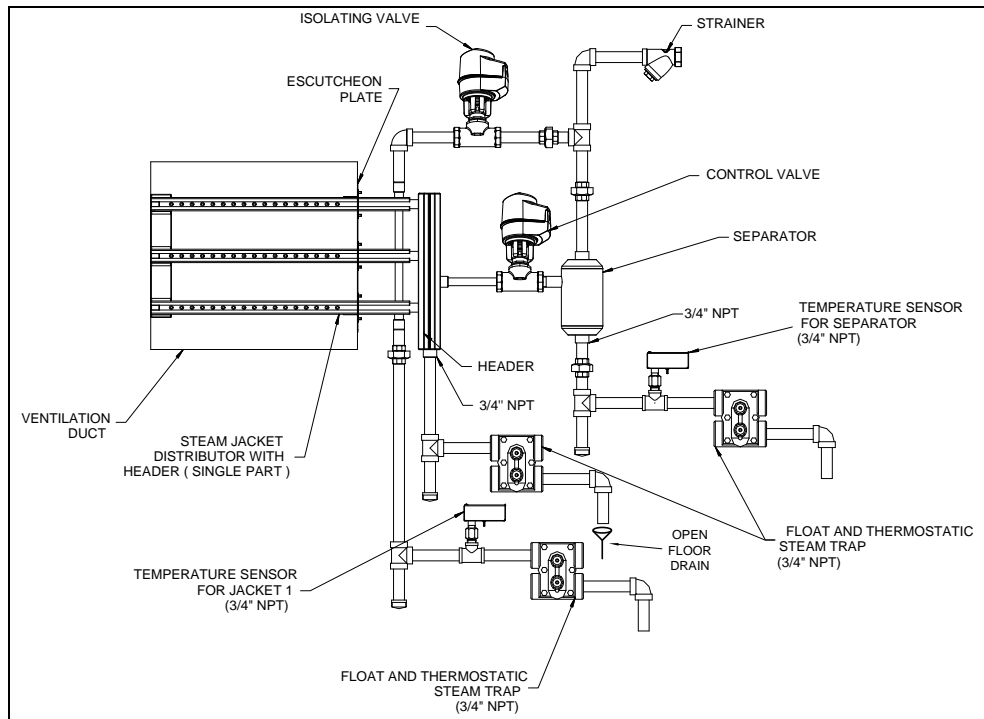

Illustration 8 - Mini Rack

Stage 3 – Control Valve (AM060) Installation



Any installation work must be carried out by suitably qualified personnel.

Control Valve Positioning

- The body of the valve must be positioned properly to have the steam supply going into the A port and exiting from the AB port. Do not refer to the orientation of the actuator head for positioning, since the head can be reversed.
- Install the actuated valve (AM060 actuator with globe valve) between 20 to 30 degrees from the vertical line to reduce the convection heat to the actuator.

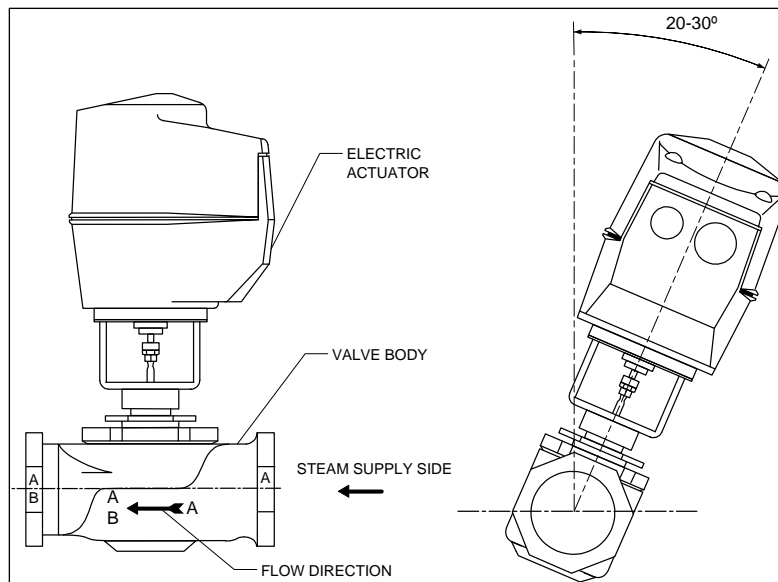

Illustration 9 - Control Valve Orientation and Angle

Control Valve Installation without Header (Jacketed Single Tube)

Use the proper size union to connect the control valve to the steam distributor. The maximum distance between the steam control valve and the dispersion tubes port must be 8" (203 mm).

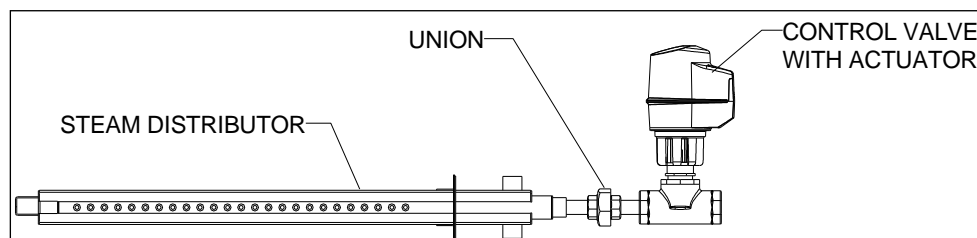

Illustration 10 - Control Valve Connection to Steam Distributor without Header

Control Valve Installation with Header (Mini Rack or Multi-Tube)

Connect the steam control valve to the steam header by using a length of threaded pipe of the proper dimension. The connection between those must not exceed 8" (203 mm) and the steam control valve port must be aligned with the header inlet port.

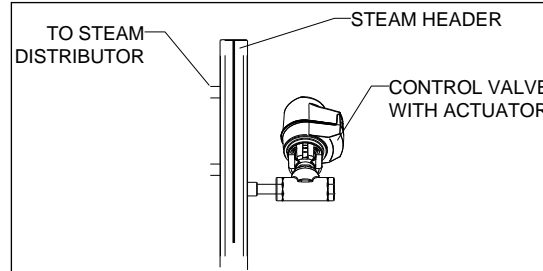

Illustration 11 - Control Valve Connection with Header

Control Valve Flow Coefficient and Capacity

Valve Size	Cv (Kv)	Separator Size	Steam Capacity (lb/h) [kg/h]			
			2 PSI (14kPa)	5 PSI (35kPa)	10 PSI (69kPa)	15 PSI (103kPa)
1/2" (DN15)	0.4 (0.3)	3/4" (DN20)	7 [3]	12 [5]	14 [7]	17 [8]
	1.3 (1.1)		22 [10]	38 [17]	47 [21]	54 [24]
	2.2 (1.9)		37 [17]	65 [29]	79 [36]	91 [41]
	4.4 (3.8)		73 [33]	129 [59]	158 [72]	182 [83]
3/4" (DN20)	5.5 (4.8)	1" (DN25)	92 [42]	161 [73]	198 [90]	227 [103]
	7.5 (6.5)		125 [57]	220 [100]	270 [123]	310 [141]
1" (DN25)	10 (8.7)	1 1/2" (DN40)	167 [76]	293 [133]	360 [164]	413 [188]
	14 (12)		233 [106]	411 [187]	504 [229]	579 [263]
1 1/4" (DN30)	20 (17)		333 [152]	587 [267]	720 [327]	827 [376]
1 1/2" (DN40)	28 (24)		467 [212]	821 [373]	1008 [458]	1157 [526]
2" (DN50)	40 (35)	2" (DN50)	667 [303]	1173 [533]	1440 [655]	1653 [752]

Stage 4 – Steam Separator Installation



Any installation work must be carried out by suitably qualified personnel.

Steam Separator Positioning

The steam separator must be installed so that the steam inlet is always on top. The steam inlet and the condensate outlet must be vertical.

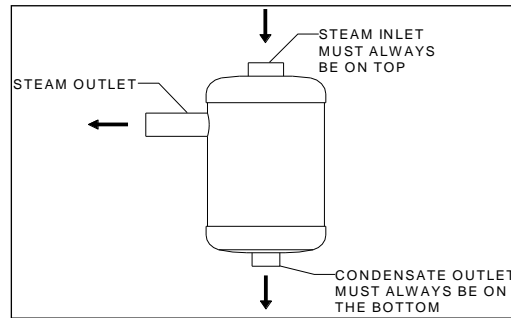

Illustration 12 - Separator Proper Installation

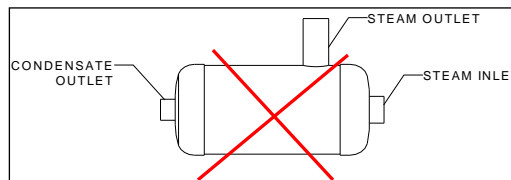

Illustration 13 - Separator Incorrect Installation

Steam Separator Installation with Jacketed Single Tube

Position the steam separator so that the steam inlet is always located on the top. The steam separator must be connected to the outlet of the jacketed distribution tube and must be positioned below the tube to avoid a buildup of condensate in any area in the piping.

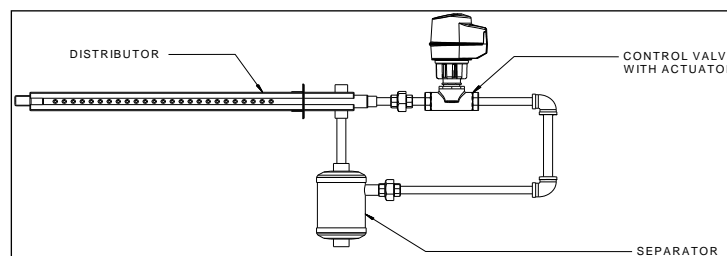

Illustration 14 - Single Steam Distributor Separator Correct Installation

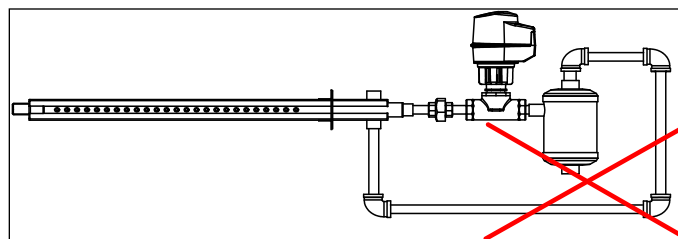

Illustration 15 - Single Steam Distributor Separator Incorrect Installation



Steam Separator Installation (Mini Rack and Multi-Tube)

Position the steam separator so that the steam inlet is always located on the top. The separator steam outlet port must be aligned with the steam control valve inlet port and the distance between the two must not exceed 8" (203 mm). Use the proper size of threaded pipe to connect the steam separator to the control valve. Reducing coupling might be needed to perform the installation between the separator and the steam control valve.

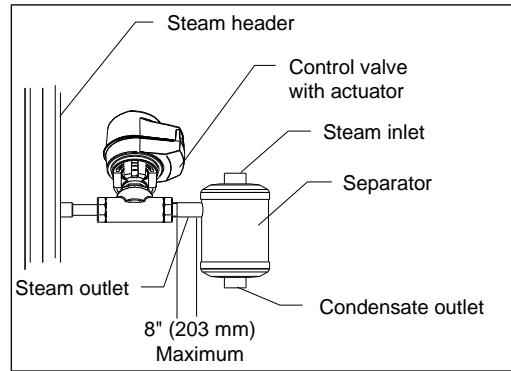

Illustration 16 - Separator Connection to Control Valve

Stage 5 – Temperature Sensor Installation



Any installation work must be carried out by suitably qualified personnel.

Temperature Sensor Installation General

- One temperature sensor shall be installed downstream of the condensate outlet of the steam separator. Refer to [Illustration 17 - Temperature Sensor Separator Installation](#).

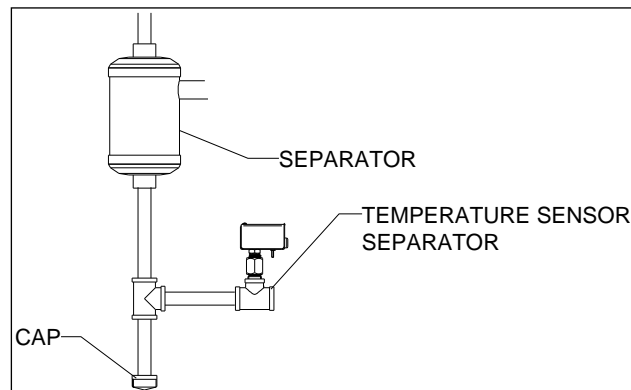

Illustration 17 - Temperature Sensor Separator Installation

- Mini Rack and Multi-Tube applications will require at least one additional temperature sensor to be installed at the outlet of the steam jacket distributor. Depending on the total steam distributor length and number, the humidifier might require up to 4 temperature sensors on the steam jacket distributors. The system requires 1 temperature sensor for each 50 linear feet (15m) of steam distributors. Refer to [Illustration 18 - Temperature Sensor Jacket Installation](#).

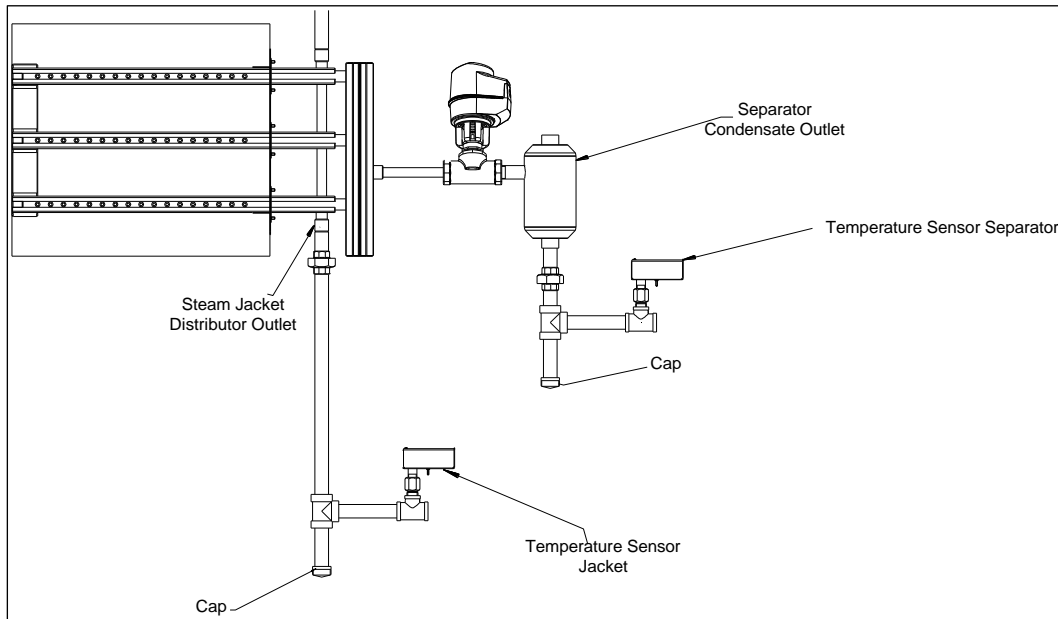

Illustration 18 - Temperature Sensor Jacket Installation

Stage 6 – Float and Thermostatic Steam Trap Installation



Any installation work must be carried out by suitably qualified personnel.

Float and Thermostat Steam Trap Installation

- Install a float and thermostatic steam trap at each condensate outlet of the Direct Steam Injection Humidifier system. Do not combine return steam lines into one steam trap. Steam traps can only be combined on the condensate side.
- The outlet of the float and thermostat steam trap must be connected to the condensate return pipe of the steam boiler system.
- The distance between the temperature sensor and the steam trap must be between 5” and 7” (100-175 mm).

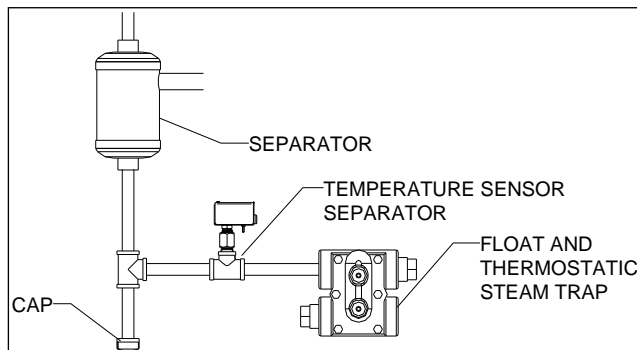

Illustration 19 - Separator Steam Trap Installation

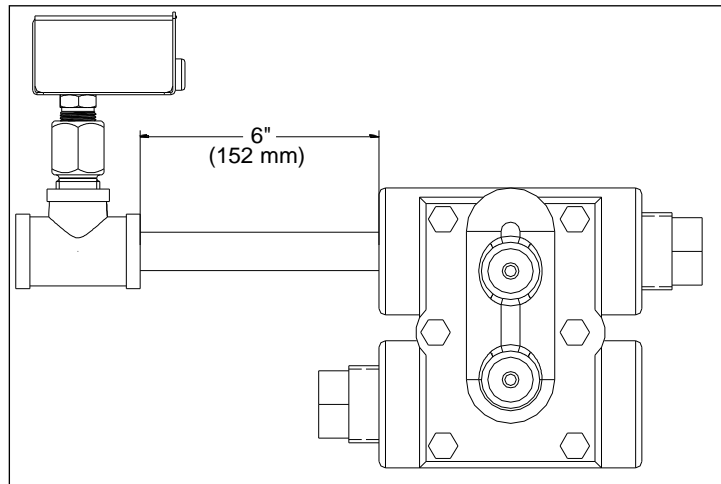

Illustration 20 - Steam Trap Installation: Distance from Temperature Sensor

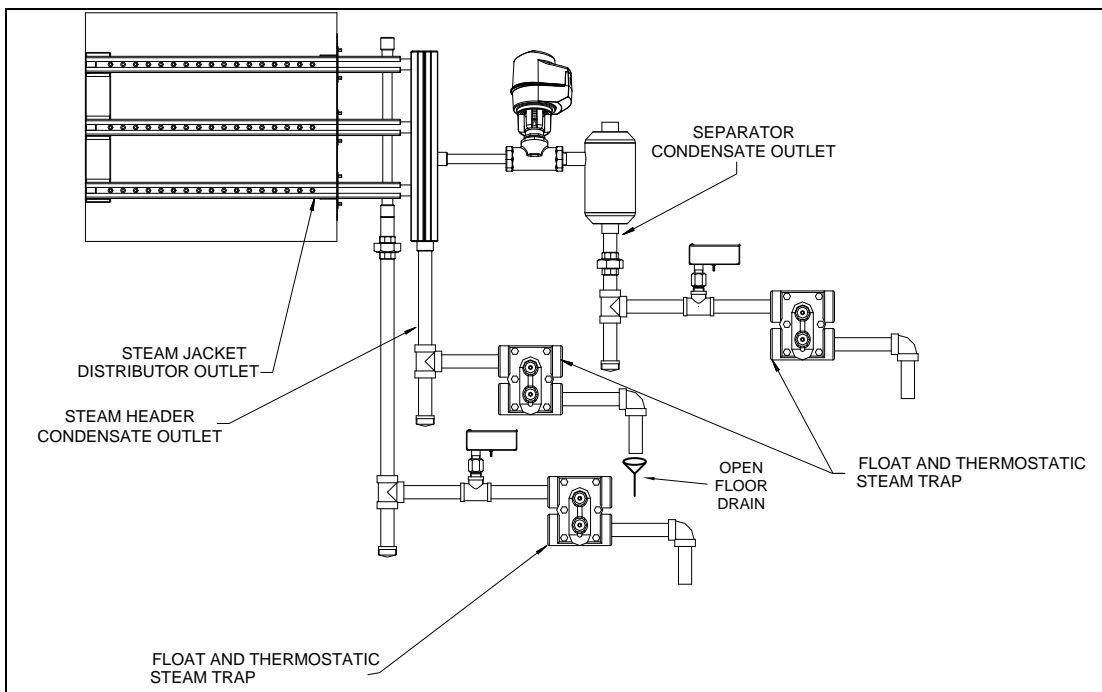

Illustration 21 - Steam Trap Installation (Mini Rack and Multi-Tube)

For Mini Rack and Multi-Tube applications, connect the header steam trap, refer to [Illustration 21 - Steam Trap Installation \(Mini Rack and Multi-Tube\)](#), to the drain since there is no pressure upstream of the steam control valve to push the condensate back to the boiler. Therefore, normal draining design applies on the condensate side of the header steam trap slope to evacuate the condensate, and a P-trap (6" or 152 mm) to avoid the steam vapor coming from the drain. All other steam traps can be connected to the condensate return line.



Any installation work must be carried out by suitably qualified personnel.

Stage 7 – Isolating Valve (AT060) Installation

Isolating Valve Positioning

- The valve body must be positioned properly to have the steam supply going into the A port and exiting from the AB port. Do not refer to the orientation of the actuator head for positioning, since the head can be reversed.
- Install the actuated valve (AT060 actuator with globe valve) between 20 to 30 degrees from the vertical line to reduce the heat transfer to the actuator head.

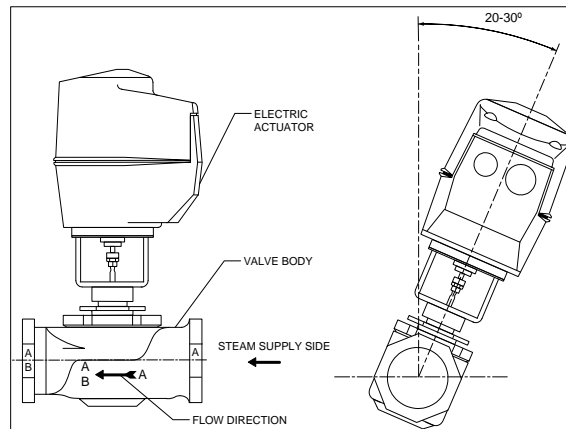

Illustration 22 - Isolating Valve Orientation and Angle

Stage 8 – Y-Strainer Installation



Any installation work must be carried out by suitably qualified personnel.

Strainer Positioning

- The strainer must be installed upstream the separator and the isolating valve for any Direct Steam Injection Humidifier configuration.
- On the Jacketed Single Tube applications, install the strainer before installing the isolating valve. Refer to *Illustration 23 - Jacketed Single Tube*.
- For Mini Rack and Multi-Tube applications, install the strainer before the steam line splits between the separator and the isolating valve. Refer to *Illustration 23 - Jacketed Single Tube*.

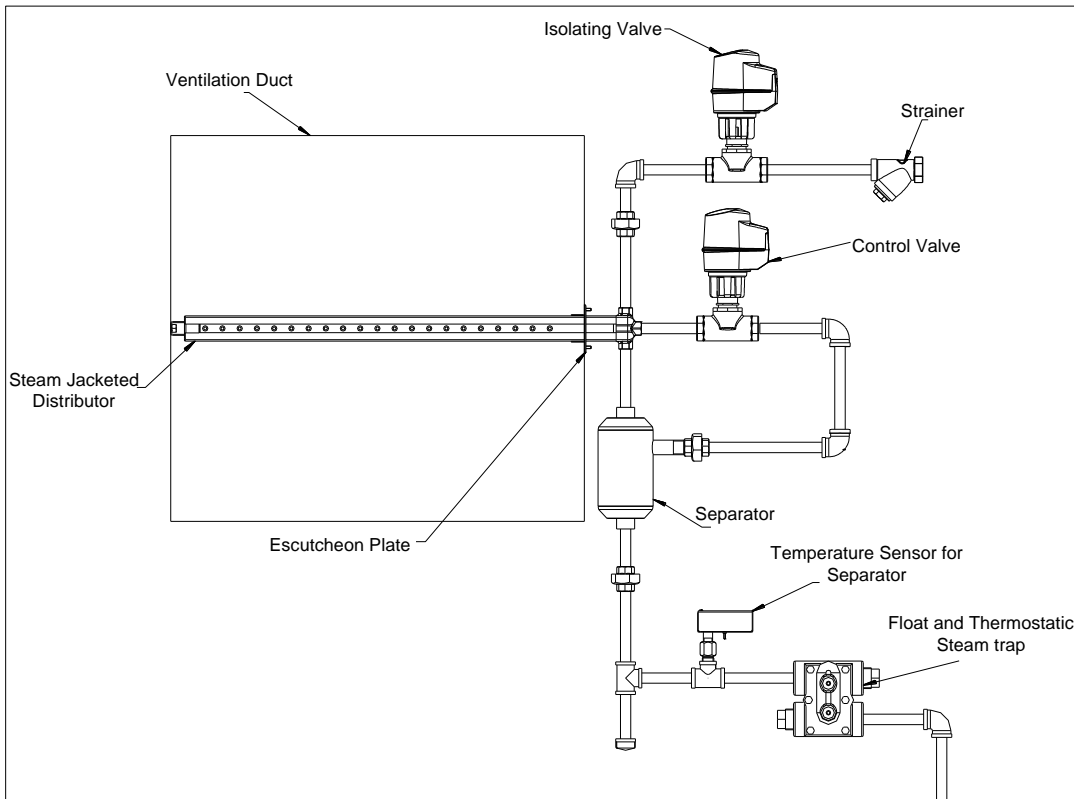

Illustration 23 - Jacketed Single Tube

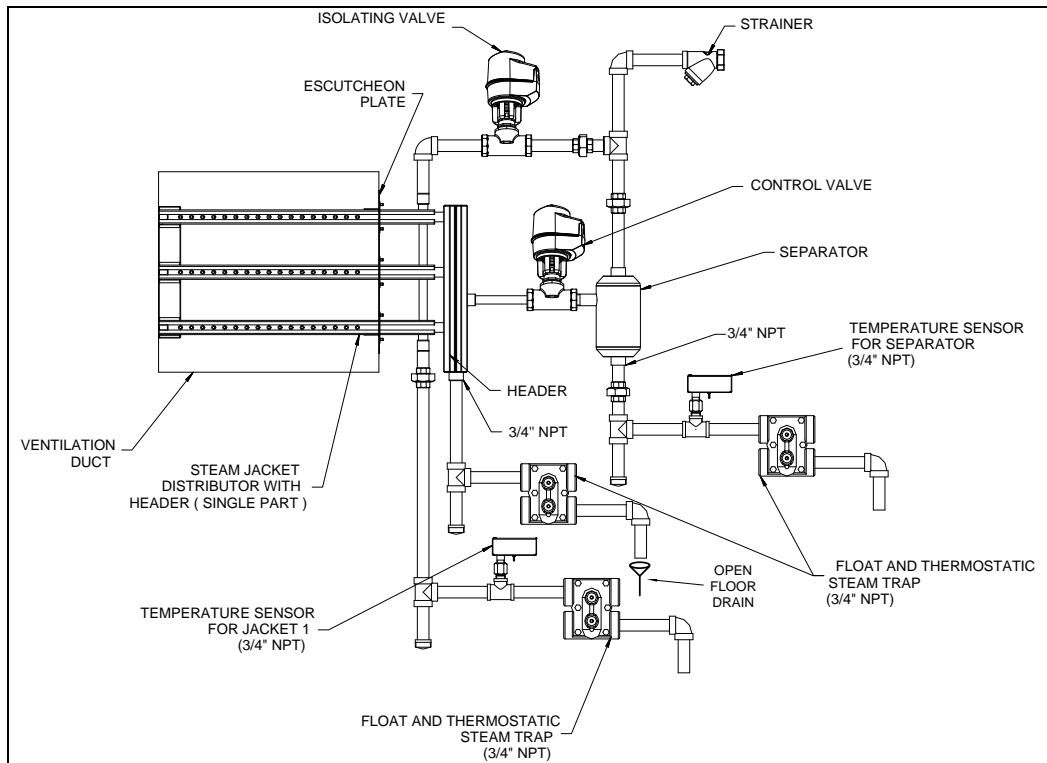

Illustration 24 - Mini Rack and Multi-Tube

Stage 9 – Electronic Steam Controller (SKDESC-J)

Models

SKDESC-J

SKDESC-JB with BACnet Communication

SKDESC-JD with Modbus Communication

Description

The Electronic Steam Controller SKDESC-J is made specifically for Neptronic SKD-J (Jacketed) Humidifiers.

Features

- Conserves energy and eliminates condensate (dry operation)
 - Manages isolating and modulating valves
 - Pre-heats tube jackets on demand for humidity
- Automatic temperature sensor adjustment
- On/Off or Modulating control
- Selectable internal or external control
- Configurable proportional control band & dead band
- Selectable Fahrenheit or Celsius scale
- BACnet or Modbus models available
- 24 Vac power supply (by others)
- Easy start up and troubleshooting
- Backlit LCD with simple icon and text driven menus



ESC Steam Controller Series

Technical Specifications

Description	SKDESC-J	SKDESC-JB	SKDESC-JD
Power Supply	24 Vac		
Power Consumption	50 VA		
Relay Output	2 relay		
Relay Rating	125 Vac, resistive load 10 amps		
Communication	-	BACnet	Modbus
Operating Temperature	32°F to 122°F (0°C to 50°C)		
Storage Temperature	-22°F to 122°F (-30°C to 50°C)		
Relative Humidity	5 to 95% non-condensing		
Weight	1.4 lb. (635 g)		
Dimensions A = 6.3" 160mm B = 5" 126mm C = 2.25" 57mm			

Wiring



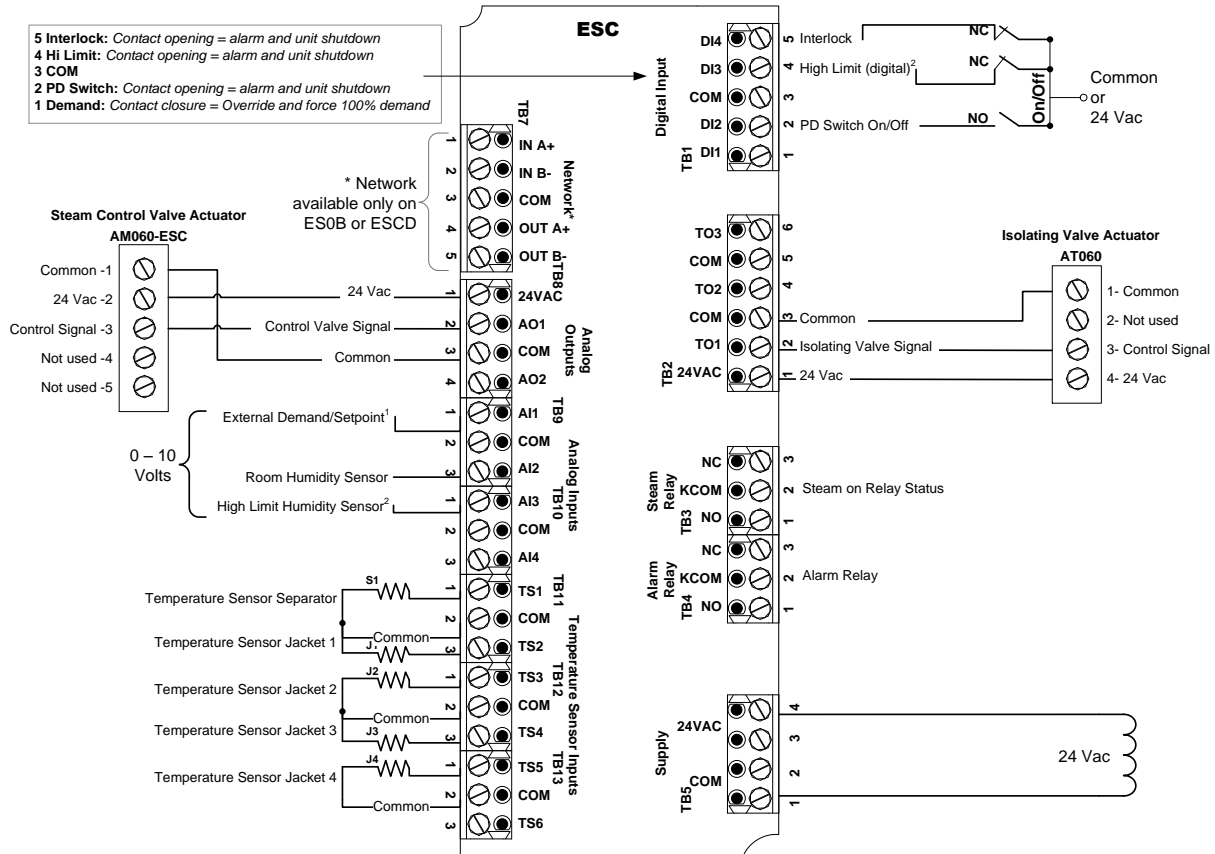

We strongly recommend that all Neptronic products be wired to a separate grounded transformer and that transformer shall service only Neptronic products. This precaution will prevent interference with, and/or possible damage to incompatible equipment.



Temperature Sensor Jackets 1-2-3-4 sensor are optional, depending on system configuration.

Step	Description	Terminal Block	
Step 11, "Control Mode" = <i>EXTERN</i>	Used for external control signal	TB9	Pin 1
Step 11 "Control Mode" = <i>INTERN</i> and Step 16, "External Humidity Setpoint" = <i>DN</i>	Used for external setpoint signal		
Step 22, "High limit sensor" = <i>DIGITAL</i>	Used for connecting high limit sensor (Digital)	TB1	Pin 4
Step 22, "High limit sensor" = <i>ANALOG</i>	Used for connecting high limit sensor (Analog)	TB10	Pin 1







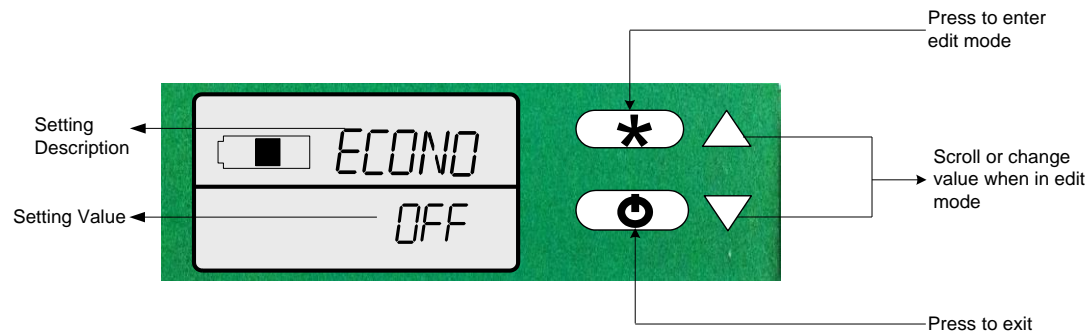

Symbols used in this manual

-  Humidity
-  Temperature
-  Communication/Network
-  Air Flow
-  Timer/Clock

Programming Mode



To enter the Programming Mode, perform the following steps:

1. Press  to start and enter password (see Step 1 "enter passwrd").
2. Use the arrows buttons  or  to navigate the menu.
3. Press  to enter edit mode of the displayed value.
4. Once in edit mode, use the arrows buttons  or  to change values. Changed values are automatically saved.
5. Press  to exit edit mode of the displayed value.
6. Return to step 2 or press  to exit the mode. Auto exits if no actions are taken after 5 minutes.

1. "ENTER PASSWRD"

 Value: 637

Enter the password within 1 minute. After entering the correct password, press  to proceed. If you enter the wrong password, the controller returns to the normal operation mode and you have to repeat this step.

2. "LANGUAG"

 Default: ENG (English)
Range: ENG (English)

Select the desired language.

3. "METRIC DISPLAY UNITS"

 Default: ON
Range: ON (metric units - °C, kg H₂O/Hr), OFF (imperial units - °F, lbs H₂O/Hr)

Select the desired measurement system.

4. "ECONO MODE"

Default: OFF (econo mode deactivated)
 Range: ON (econo mode activated), OFF (econo mode deactivated)

In Econo mode, the isolation valve will be closed when there is no demand.



*Important: For correct operation, set the econo mode feature to **OFF** (econo mode deactivated).*

5. "WORKING CAPACIT IN PCT"

Default: 100%
 Range: 10 to 100%
 Increment: 5%

This option enables you to adjust the maximum demand capacity of the full system capacity in %. This percentage is a factory setting. We recommend that you do not change this value without consulting Neptronic.

6. "SEPARAT TEMPER OFFSET"

Default: 0
 Range: -10 to 10°C [-18 to 18°F]
 Increment: 0.1°C [0.1°F]

Set the desired temperature reading.

7. "JACKET1 TEMPER OFFSET"

Default: 0
 Range: -10 to 10°C [-18 to 18°F]
 Increment 0.1°C [0.1°F]

This option appears only if the number of temperature switches is greater than 1. Adjust the temperature reading by using the offset.

8. "JACKET2 TEMPER OFFSET"

Default: 0
 Range: -10 to 10°C [-18 to 18°F]
 Increment: 0.1°C [0.1°F]

This option appears only if the number of temperature switches is greater than 2. Adjust the temperature reading by using the offset.

9. "JACKET3 TEMPER OFFSET"



Default: 0
 Range: -10 to 10°C [-18 to 18°F]
 Increment: 0.1°C [0.1°F]

This option appears only if the number of temperature switches is greater than 3. Adjust the temperature reading by using the offset.

10. "JACKET4 TEMPER OFFSET"

Default: 0
 Range: -10 to 10°C [-18 to 18°F]
 Increment: 0.1°C [0.1°F]

This option appears only if the number of temperature switches is greater than 4. Adjust the temperature reading by using the offset.

11. "CONTROL MODE"

 Default: Extern
 Range: Intern, Extern, Net

Select the desired control mode from the available options.

- If Intern is selected: the humidifier is controlled by the SKDESC-J.
- If Extern is selected: the humidifier is controlled by an external signal.
- If Net is selected: the humidifier is controlled over the network. This option is available only on SKDESC-JB and SKDESC-JD models.

If you selected Intern or Net, go to Step 13 "network room humidity".

12. "DEMAND SIGNAL RANGE"

 Default: 2-10 Vdc
 Range: 0-10 Vdc, 2-10 Vdc

Select the desired relative humidity sensor signal.

13. "NETWORK ROOM HUMIDITY"

 Default: OFF
 Range: OFF, ON

This option is only available on BACnet or Modbus models (SKDESC-JB or SKDESC-JD). Select **ON** if you want to control the humidity over the network.

If you selected ON, go to Step 16 "External Humidity Setpoint".

If you selected Intern at Step 11 "Control Mode", go to Step 15 "Room humidity signal range".

14. "ROOM HUMIDITY OFFSET IN PCT"

 Default: 0% RH
 Range: -10 to 10% RH
 Increment: 0.1% RH

Adjust the room relative humidity reading by using the offset.

15. "ROOM HUMIDITY SIGNAL RANGE"

 Default: 2-10 Vdc
 Range: 0-10 Vdc, 2-10 Vdc

Select the desired signal range from the available options.

If you selected Extern at Step 11 "Control Mode", go to Step 22 "High limit sensor".

16. "EXTERNAL HUMIDITY SETPOINT"

 Default: OFF
 Range: OFF, ON

Select **ON** if you want to use an external setpoint for humidity.

If you selected OFF, go to Step 18 "Internal humidity setpoint in pct".

17. "SETPOINT SIGNAL RANGE"

 Default: 2-10 Vdc
 Range: 0-10 Vdc, 2-10 Vdc

Select the desired relative humidity sensor signal. Go to Step 19 "control dead band in pct".

18. "INTERNA HUMIDTY SETPNT IN PCT"

Default: 40% RH
 Range: 10% to 90% RH
 Increment: 1% RH

Set the desired humidity setpoint in % RH.

19. "CONTROL DEAD BAND IN PCT"

Default: 2.0% RH
 Range: 0% to 5% RH
 Increment: 0.1% RH

Set the desired control dead band.

20. "CONTROL PROP RAMP IN PCT"

Default: 5.0%
 Range: 1% to 10%
 Increment: 0.1%

Set the desired control proportional ramp.

21. "CONTROL INTEGRA RAMP IN PCT"

Default: 5.0%
 Range: 1% to 10%
 Increment: 0.1%

Set the desired control integral ramp.

22. "HIGH LIMIT SENSOR"

Default: Digital (On/Off)
 Range: Disable, Analog, Digital (On/Off), Network

Select the desired type of high limit sensor from the available options. The Network option is available only on BACnet or Modbus models (SKDESC-JB or SKDESC-JD).

If you selected Digital, go to Step 27 "High limit max demand in pct".

If you selected Disable, go to Step 28 "end of season delay in hr".

23. "HIGH LIMIT SETPNT IN PCT"

Default: 80% RH
 Range: 10% to 90% RH
 Increment: 1% RH

Set the high limit relative humidity setpoint.

24. "HIGH LIMIT PROP RAMP IN PCT"

Default: 10.0 %
 Range: 0% to 20%
 Increment: 0.1%

Set the desired high limit proportional ramp.

If you selected Network at Step 22 "High limit sensor", go to Step 27 "High limit max demand in pct".

25. "HIGH LIMIT HUMIDTY OFFSET IN PCT"

Default: 0% RH
 Range: -10% RH to 10% RH
 Increment: 0.1% RH

Adjust the relative humidity reading of the room.

26. "HIGH LIMIT SIGNAL RANGE"

 Default: 2-10 Vdc
 Range: 0-10 Vdc, 2-10 Vdc

 Select the high limit signal range.

27. "HIGH LIMIT MAX DEMAND IN PCT"

Default: No default (information display only)

 Displays the actual reading of the high limit sensor.

28. "END OF SEASON DELAY IN HR"

 Default: 100 hours
 Range: 100 to 250 hours
 Increment: 5 hours

 This option does not appear if you have selected **econo mode** at Step 4 "econo mode". Indicates that the isolation valve will be turned off after 100 hours if there is no demand.



29. "SERVICE DELAY IN HR"

 Default: 1000 hours
 Range: 400 to 1500 hours
 Increment: 100 hours

 Set the number of hours running at 100% capacity before servicing is due.

30. "SERVICE RUNTIME IN HR"

Default: No default (information display only)

 Displays the running time in hours at 100% capacity since the last service has been performed. To reset this value to 0 and reset any associated alarms, press the edit  button and then press and hold both  and  arrow keys.

31. "RUNS WHILE SERVICE ALARM"

 Default: ACt (active)
 Range: INACt (Inactive), ACt (active)

 Select **ACt** to enable the system to run even when the servicing is due.

32. "TOTAL RUNTIME IN HR"

Default: No default (information display only)

 Displays the running time in hours at 100% capacity.

33. "AUTO BAUD RATE"

 Default: ON
 Range: ON, OFF

 This option is available only on BACnet or Modbus models (SKDESC-JB or SKDESC-JD). Enable or disable Auto Baud Rate detection. When enabled, the controller automatically configures its baud rate by detecting the network speed upon connection to the network. When disabled, you must manually select the baud rate. (**go to Step 34, "baud rate"**)

34. "BAUD RATE"

Default: No default (information display only)
 Range:
 BACnet 9.6k, 19.2k, 38.4k, 76.8k
 Modbus 9.6k, 19.2k, 38.4k, 57.6k

This option is available only on BACnet or Modbus models (SKDESC-JB or SKDESC-JD). If you selected **ON** at the previous step, the controller automatically detects and displays the baud rate. If you selected **OFF** at the previous step, select the baud rate value from the available options.

35. "NETWORK ADDRESS"

BACnet
 Default: 0
 Range: 0 to 254
 Modbus
 Default: 1
 Range: 1 to 246

This option is available only on BACnet or Modbus models (SKDESC-JB or SKDESC-JD). Select the desired address.

36. "ADJUST DEVICE INSTANCE"

Default: 0153001
 Range: No, Yes

To change the device instance, select **Yes**. If you select **No**, the device instance will be modified automatically according to the MAC address.

37. "NETWORK PARITY"

Default: None
 Range: None, Odd, Even

This option is available only on Modbus model (SKDESC-JD). Select the desired parity control from the available options.

38. "NETWORK STOP BITS"

Default: 1
 Range: 1,2

This option is available only on Modbus model (SKDESC-JD). Select the desired network stop bits.

39. "NETWORK FALLBACK TIMEOUT"

Default: 0 sec
 Range: 0 to 900 sec
 Increment: 1 sec

This option appears if you've set one of the inputs to **Net** at Step 11 "Control Mode". Set the desired network fallback timeout.

40. "NETWORK FALLBACK SETPOINT"

Default: 0.0%
 Range: 0% to 100%
 Increment: 0.1%

This option appears if you've set one of the inputs to **Net at Step 11** "Control Mode". Set the desired network fallback setpoint.

41. "NETWORK FALLBACK COUNTER"

Default: 0 sec
Range: 0 to 900 sec
Increment: 1 sec

This option appears if you've set one of the inputs to **Net at Step 11** "Control Mode". Set the desired network fallback counter.

42. "CONTROL OUTPUT SIGNAL IN MV"

Default: No default (information display only)

Displays the control valve output in mV.

43. "ISOLAT VALVE OUTPUT STATE"

Default: No default (information display only)
Range: INACt (closed), ACt (open)

Displays whether the isolating valve is open or closed.

44. "ALARM RELAY OUTPUT STATE"

Default: No default (information display only)
Range: INACt (closed), ACt (open)

Displays whether the alarm relay is open or closed.

45. "STEAM ON OUTPUT RELAY OUTPUT STATE"

Default: No default (information display only)
Range: INACt (closed), ACt (open)

Displays whether the steam output relay is open or closed.

46. "SEPARAT TEMPER INPUT SIGNAL IN MV"

Default: No default (information display only)

Displays the separator temperature sensor reading in mV.

47. "JACKET1 TEMPER INPUT SIGNAL IN MV"

Default: No default (information display only)

This option appears only if the number of temperature switches is greater than 1. Displays the jacket temperature sensor reading in mV.

48. "JACKET2 TEMPER INPUT SIGNAL IN MV"



Default: No default (information display only)

This option appears only if the number of temperature switches is greater than 2. Displays the jacket temperature sensor reading in mV.

49. "JACKET3 TEMPER INPUT SIGNAL IN MV"



Default: No default (information display only)

This option appears only if the number of temperature switches is greater than 3. Displays the jacket temperature sensor reading in mV.

50. "JACKET4 TEMPER INPUT SIGNAL IN MV"



Default: No default (information display only)

This option appears only if the number of temperature switches is greater than 4. Displays the jacket temperature sensor reading in mV.

51. "DEMAND INPUT SIGNAL IN MV"



Default: No default (information display only)

This option appears only if you've selected **Extern** at Step 11 "Control Mode". Displays the reading of demand in mV.

52. "ROOM HUMIDITY INPUT SIGNAL IN MV"



Default: No default (information display only)

This option does not appear if you've selected **OFF** at Step 13 "network room humidity". Displays the relative humidity reading of the room in mV.

53. "SETPNT INPUT SIGNAL IN MV"



Default: No default (information display only)

This option appears only if you've selected **ON** at Step 16 "Externa Humidity Setpnt". Displays the setpoint reading in mV.

54. "HIGH LIMIT INPUT SIGNAL IN MV"



Default: No default (information display only)

This option appears only if you've selected **Analog** at Step 22 "High limit sensor". Displays the high limit sensor reading in mV.

55. "EXTERN DEMAND INPUT STATE"



Default: No default (information display only)
Range: INACt (closed), ACt (open)

This option appears only if you've selected **Extern** at Step 11 "Control Mode". Displays if the demand is open or closed.

56. "AIR FLOW INPUT STATE"

Default: No default (information display only)
Range: INACt (closed), ACt (open)

Displays if the air flow switch is open or closed.

57. "HIGH LIMIT SWITCH INPUT STATE"

Default: No default (information display only)
Range: INACt (closed), ACt (open)

This option appears only if you've selected **Digital** at Step 22 "High limit sensor". Displays if the high limit switch is open or closed.

58. "INTRLCK INPUT STATE"

Default: No default (information display only)
Range: INACt (closed), ACt (open)

Displays if the interlock is open or closed.

59. "MICRO TEMPER"

Default: No default (information display only)

Displays whether the microcontroller temperature is in °C or °F mode.

60. "PCB TEMPER"

Default: No default (information display only)

Displays whether the PCB temperature is in °C or °F mode.

Alarms and Notifications

The following is a list of alarms and notifications displayed by the Steam Controller under different conditions. When each one of these occurs, the controller performs certain actions as described in the table. The alarm symbol, \triangle is displayed along with the all the alarms and notifications.

Display	Description
<i>NO AIR FLOW ALARM</i>	<p>Indicates that the air flow sensor is not detected.</p> <ul style="list-style-type: none"> - control valve is closed - isolating valve is closed
<i>HIGH LIMIT CUTOUT ALARM</i>	<p>Indicates that the duct humidity has exceeded the high limit level.</p> <ul style="list-style-type: none"> - control valve is closed - isolating valve is closed - alarm relay is activated
<i>SERVICE WARNING ALARM</i>	<p>Indicates that the servicing is due in less than 100 hours.</p> <ul style="list-style-type: none"> - alarm relay is activated <p>Service the unit and reset the unit by pressing the arrow keys \triangle, ∇ for three seconds.</p>
<i>SERVICE UNIT ALARM</i>	<p>Indicates that the service is due. This alarm is displayed only if you've set the option to <i>INACT</i> at Step 31 "runs while service alarm".</p> <ul style="list-style-type: none"> - control valve is closed - isolating valve is closed - alarm relay is activated
<i>INTER LOCK ALARM</i>	<p>Indicates that the inter lock is activated.</p> <ul style="list-style-type: none"> - control valve is closed - isolating valve is closed - alarm relay is activated
<i>FLOODED SEPARATE STEAM TRAP FAILURE</i>	<p>Indicates that either the separator steam trap is flooded or the temperature is too low.</p> <ul style="list-style-type: none"> - control valve is closed - alarm relay is activated
<i>FLOODED JACKET1 STEAM TRAP FAILURE</i>	<p>Indicates that either the jacket steam trap is flooded or the temperature is too low.</p> <ul style="list-style-type: none"> - control valve is closed - alarm relay is activated
<i>FLOODED JACKET2 STEAM TRAP FAILURE</i>	<p>Indicates that either the jacket 2 steam trap is flooded or the temperature is too low.</p> <ul style="list-style-type: none"> - control valve is closed - alarm relay is activated
<i>FLOODED JACKET3 STEAM TRAP FAILURE</i>	<p>Indicates that either the jacket 3 steam trap is flooded or the temperature is too low.</p> <ul style="list-style-type: none"> - control valve is closed - alarm relay is activated
<i>FLOODED JACKET4 STEAM TRAP FAILURE</i>	<p>Indicates that either the jacket 4 steam trap is flooded or the temperature is too low.</p> <ul style="list-style-type: none"> - control valve is closed - alarm relay is activated
<i>SEPARAT TEMPER SENSOR FAILURE</i>	<p>Indicates that the separator sensor is defective.</p> <ul style="list-style-type: none"> - control valve is closed - isolating valve is closed - alarm relay is activated



Display

Description

<i>JACKET1 TEMPER SENSOR FAILURE</i>	Indicates that the jacket sensor is defective. <ul style="list-style-type: none">- control valve is closed- isolating valve is closed- alarm relay is activated
<i>JACKET2 TEMPER SENSOR FAILURE</i>	Indicates that the jacket 2 sensor is defective. <ul style="list-style-type: none">- control valve is closed- isolating valve is closed- alarm relay is activated
<i>JACKET3 TEMPER SENSOR FAILURE</i>	Indicates that the jacket 3 sensor is defective. <ul style="list-style-type: none">- control valve is closed- isolating valve is closed- alarm relay is activated
<i>JACKET4 TEMPER SENSOR FAILURE</i>	Indicates that the jacket 4 sensor is defective. <ul style="list-style-type: none">- control valve is closed- isolating valve is closed- alarm relay is activated
<i>ROOM HUMIDITY SENSOR FAILURE</i>	Indicates that the room humidity sensor has failed. <ul style="list-style-type: none">- control valve is closed- isolating valve is closed- alarm relay is activated
<i>HIGH LIMIT HUMIDITY SENSOR FAILURE</i>	Indicates that the high limit humidity sensor has failed. <ul style="list-style-type: none">- control valve is closed- isolating valve is closed- alarm relay is activated

Power Up

Upon power up, the LCD illuminates and all segments appear for 2 seconds. The thermostat then displays its serial number, model, and revision for 2 seconds. In the Operation Mode, the information is displayed automatically in a sequence. If you wish to scroll the information quickly, use the Δ , ∇ arrow keys.

Humidity Levels

The following humidity levels are displayed:

- *HUMIDITY SETPOINT IN PCT* - Humidity setpoint in % RH
- *ROOM HUMIDITY IN PCT* - Room humidity reading in % RH
- *HIGH LIMIT HUMIDTY IN PCT* - Duct sensor reading in % RH

Control Parameters

The following control parameters are displayed:

- *CONTROL DEMAND IN PCT* - Current demand of the total system capacity measured in %
- *CONTROL OUTPUT IN PCT* - Current output of the total system capacity measured in %
- *CONTROL DEMAND* - Current demand measured in kg/hr or lbs/hr
- *CONTROL OUTPUT* - Current output measured in kg/hr or lbs/hr

Temperature Levels

The following temperature levels are displayed:

- *SEPARAT TEMPER* - Separator temperature measured in °C or °F
- *JACKET 1 TEMPER* - Jacket 1 temperature measured in °C or °F
- *JACKET 2 TEMPER* - Jacket 2 temperature measured in °C or °F
- *JACKET 3 TEMPER* - Jacket 3 temperature measured in °C or °F
- *JACKET 4 TEMPER* - Jacket 4 temperature measured in °C or °F

Initial Verification



Any installation work must be carried out by suitably qualified personnel.

Installation

- Ensure that the humidifier is installed properly according to the installation manual.
- Check that steam distributors are properly installed into the ventilation duct.
- Ensure that there is no leakage on the Direct Steam Injection Humidifier piping.

Electrical

- Confirm that 24Vac is present between tab 1&4 of terminal block TB5 on the SKDESC-J Controller.

Drain if Needed (Mini Rack or Multi-Tube)

- If there is a steam trap on the header, confirm that the drain piping is properly connected with a pitch of at least $\frac{1}{4}$ " (6.5mm) per foot (300mm). There is no header on the Jacketed Single Tube configuration and therefore there is no steam trap on the header.

Steam Supply

- If there is a steam trap on the header, confirm that the drain piping is properly connected with a pitch of at least $\frac{1}{4}$ " (6.5mm) per foot (300mm). There is no header on the Jacketed Single Tube configuration and therefore there is no steam trap on the header.

Controls

- Ensure that a high limit duct humidistat is installed, properly connected to the SKDESC-J and the set point is properly adjusted.
- Verify that the room humidistat or returned air duct humidistat is installed, properly connected to the SKDESC-J, and the set point is properly adjusted.
- Turn on the power at the disconnect switch.
- Confirm the control set-up of the humidifier. The humidifier is factory set with EXTERNAL control set-up, which means that the humidity demand is controlled by the room or duct humidistat.
- Ensure that the type of signal (0-10 Vdc, 2-10 Vdc or 4-20 mA) of the humidistat corresponds to the type set in the humidifier control set-up.



Start-Up Procedure

Start-up

Proceed to start-up the humidifier as follows:

- Make sure that the steam is supplied to the Direct Steam Injection Humidifier.
- Switch on the SKDESC-J.
- Make sure that there is no alarm. If the A6 alarm stays on, it means that the steam does not reach the separator or there is a problem with evacuating the condensate from the separator steam trap.
- Wait for a call for humidity or create it by setting the SKDESC-J “Control Mode” to “Internal” (step # 11), and the “Externa Humidity Setpnt” to OFF (step #16). Then, adjust the set point to a higher value than the room humidity reading (operation mode B).
- Set the SKDESC-J econo mode to ON.
- The isolating valve will open within 30 seconds. If not, check for alarms (no air flow, enable/disable off). If there is no alarm, there is no humidity demand. Make sure there is a demand and redo start up procedure (d).
- After the isolating valve opens, the temperature of the jacket will increase. Within 30 seconds, the temperature of the jacket will be higher than 212°F (100°C). The temperature is displayed on the SKDESC-J LCD.
- Once the temperature is high enough, the control valve will open slowly.
- The start-up is completed and the humidifier is now functional.

Safety Test

- Check for steam or condensate leakage while the humidifier is in operation.

Reset the Set Point and Control Mode

- If the humidity set point is controlled by the SKDESC-J, reset the set point to the desired relative humidity % (set #20) as suits the room.
- If the humidity set point is controlled by another device than the SKDESC-J, set the internal control signal to OFF.

End

- The humidifier is ready for normal operation.



neptronic[®]

400 Lebeau blvd, Montreal, Qc, H4N 1R6, Canada

www.neptronic.com

Toll free in North America: 1-800-361-2308

Tel.: (514) 333-1433

Fax: (514) 333-3163

Customer service fax: (514) 333-1091

Monday to Friday: 8:00am to 5:00pm (Eastern time)